

Timing Belt

PERIODIC MAINTENANCE SERVICES

7. Timing Belt

A: REPLACEMENT

1. NON-TURBO MODEL

- 1) Remove the radiator fan and air conditioner fan. <Ref. to CO(H4SO)-33, TURBO MODEL, REMOVAL, Radiator Main Fan and Fan Motor.> <Ref. to CO(H4SO)-39, Radiator Sub Fan and Fan Motor.>
- 2) Protect the radiator with cardboard and blanket.
- 3) Remove the V-belt covers.

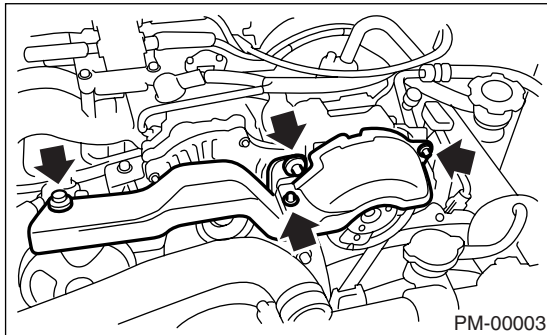

- 4) Remove the V-belts. <Ref. to ME(H4SO)-37, V-belt.>
- 5) Remove the A/C compressor V-belt tensioner.
- 6) Using the ST, lock the crankshaft and remove pulley bolt.

ST 499977100 CRANK PULLEY WRENCH

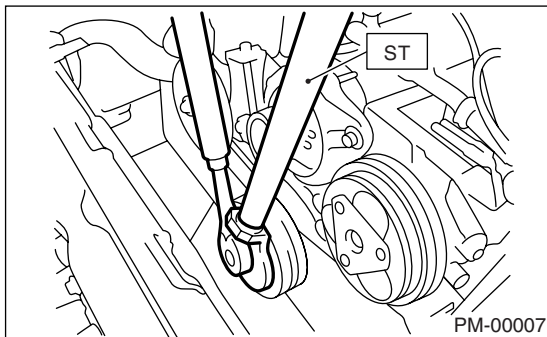

- 7) Remove the crank pulley.
- 8) Remove the belt cover LH.
- 9) Remove the front timing belt cover.
- 10) Remove the timing belt guide. (MT model)

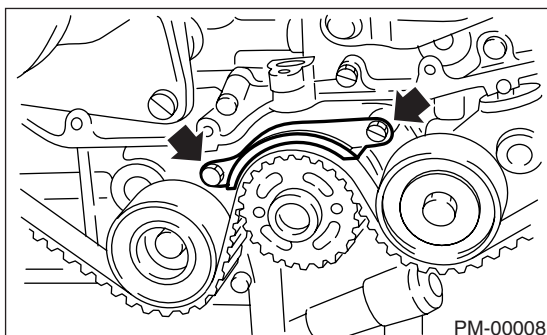

- 11) Turn the crankshaft and align the alignment marks on crankshaft, and left and right cam sprockets with notches of belt cover and cylinder block. ST 499987500 CRANKSHAFT SOCKET

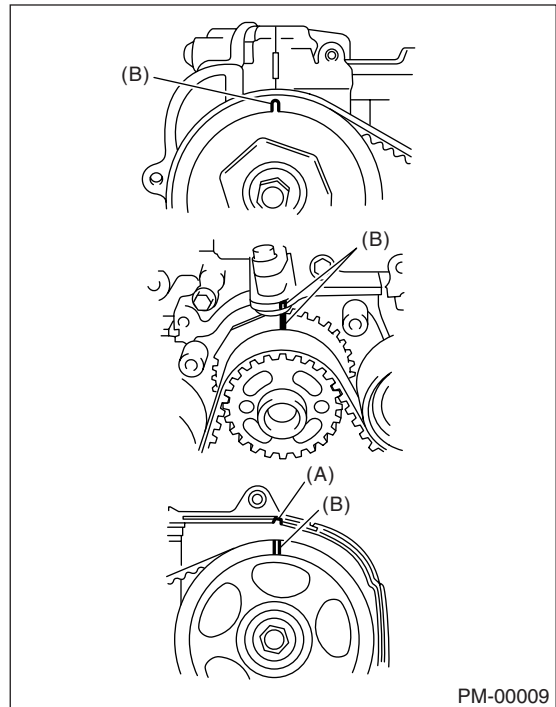

- (A) Notch
(B) Alignment mark

- 12) Remove the belt idler.
- 13) Remove the belt idler (No. 2).

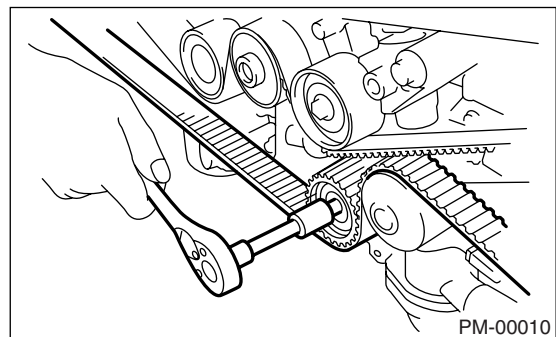

- 14) Remove the timing belt.

15) Remove the automatic belt tension adjuster assembly.

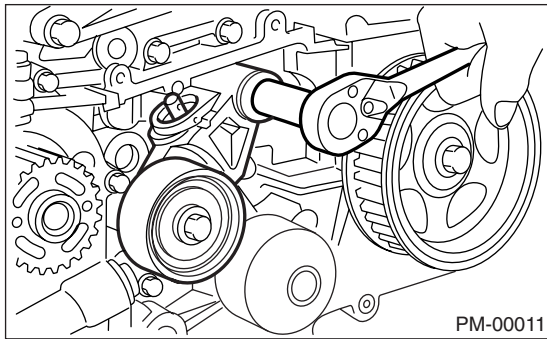

16) Install in the reverse order of removal. <Ref. to ME(H4SO)-42, INSTALLATION, Timing Belt.>

2. TURBO MODEL

1) Remove the radiator fan and air conditioner fan. <Ref. to CO(H4SO)-32, Radiator Main Fan and Fan Motor.> <Ref. to CO(H4SO)-39, Radiator Sub Fan and Fan Motor.>

2) Protect the radiator with cardboard and blanket.
3) Remove the V-belts. <Ref. to ME(H4SO)-37, V-belt.>

4) Remove the A/C compressor V-belt tensioner.
5) Using the ST, lock the crankshaft and remove pulley bolt.

ST 499977100 CRANK PULLEY WRENCH

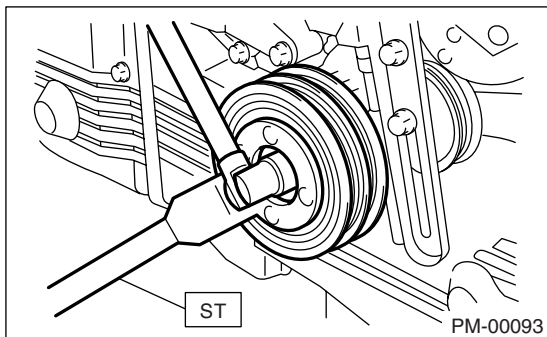

- 6) Remove the crank pulley.
- 7) Remove the belt cover (LH).
- 8) Remove the belt cover (RH).
- 9) Remove the front belt cover.

10) Remove the timing belt guide. (MT model)

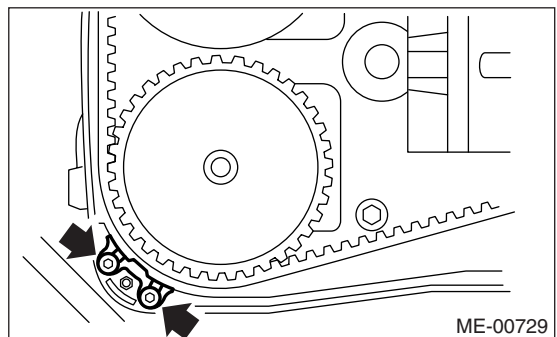
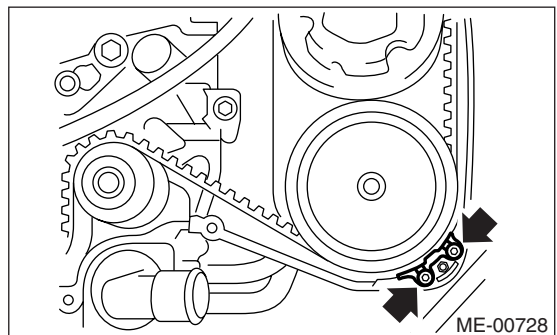
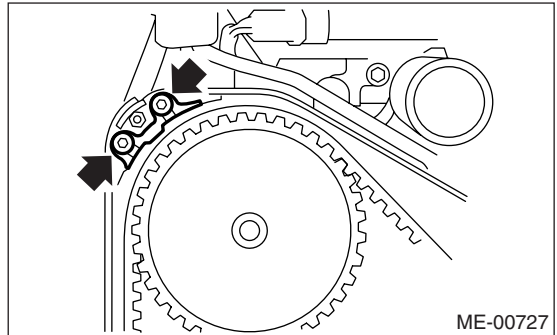
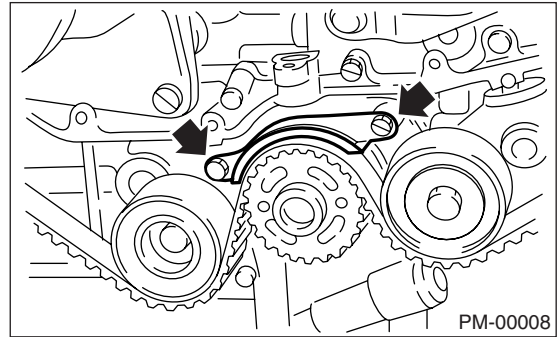

Timing Belt

PERIODIC MAINTENANCE SERVICES

11) Turn the crankshaft and align the alignment marks on crankshaft, and left and right cam sprockets with notches of belt cover and cylinder block. Use the ST to turn crankshaft.

ST 499987500 CRANKSHAFT SOCKET

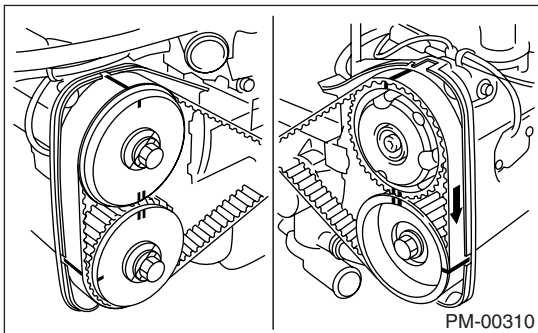
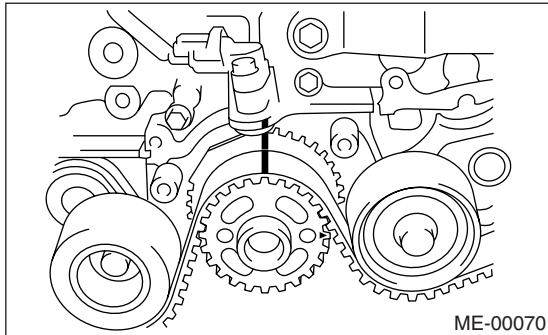

12) Remove the belt idler.

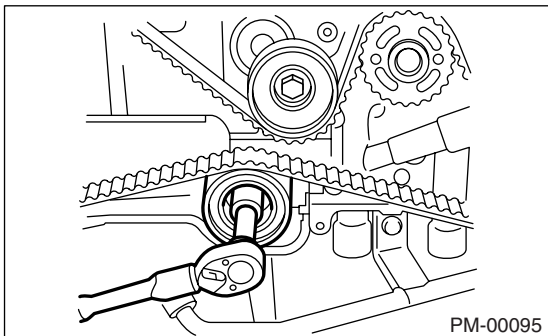

13) Remove the timing belt.

14) Remove the automatic belt tension adjuster assembly.

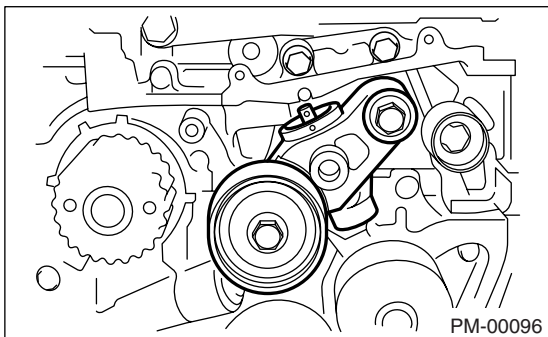

15) Install in the reverse order of removal. <Ref. to ME(H4DOTC)-44, INSTALLATION, Timing Belt.>

CAUTION:

When installing the timing belt, be sure to align all alignment marks on the belt with corresponding marks on the sprockets. If incorrectly installed, interference between pistons and valves may occur.

B: INSPECTION

1. SOHC MODEL

- 1) Remove the front timing belt cover and timing belt cover (LH).
- 2) While cranking engine at least four rotations, check the timing belt back surface for cracks or damage. Replace the faulty timing belt as needed.
- 3) Measure the timing belt width W. If it is less than 27 mm (1.06 in), check the idlers, tensioner, water pump pulley and cam sprocket to determine idler alignment (squareness). Replace the worn timing belt.

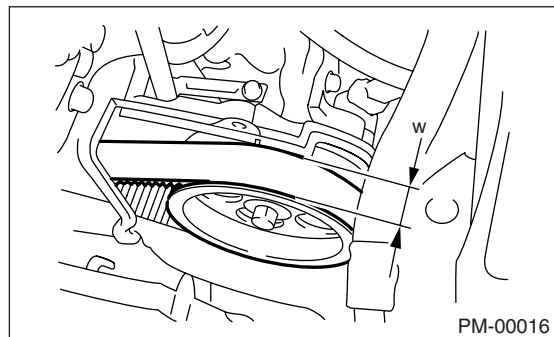

- 4) Install the front timing belt cover and timing belt cover (LH).

2. DOHC MODEL

- 1) Remove the timing belt cover (LH).
- 2) While cranking engine at least four rotations, check the timing belt back surface for cracks or damage. Replace the faulty timing belt as needed.
- 3) Measure the timing belt width W. If it is less than 29 mm (1.14 in), check the idlers, tensioner, water pump pulley and cam sprocket to determine idler alignment (squareness). Replace the worn timing belt.

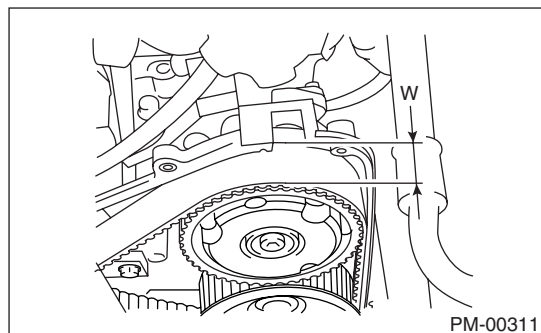

- 4) Install the timing belt cover (LH).