

# Engine Oil

## PERIODIC MAINTENANCE SERVICES

### 3. Engine Oil

#### A: REPLACEMENT

1) Open the engine oil filter cap for quick draining of engine oil.

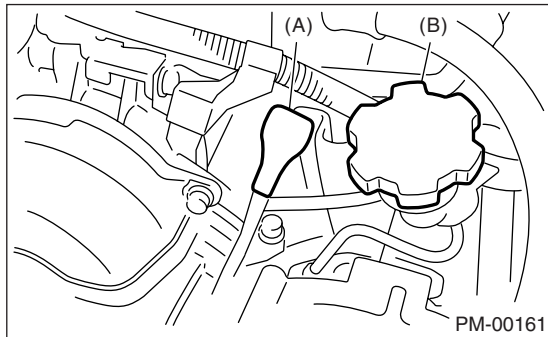

- (A) Oil level gauge
- (B) Engine oil filter cap

2) Remove the service hole cover clip.

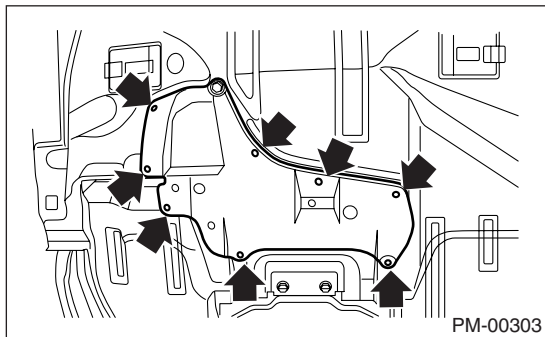

3) Turn the service hole cover in the counterclockwise direction (looking from the bottom side of the vehicle).

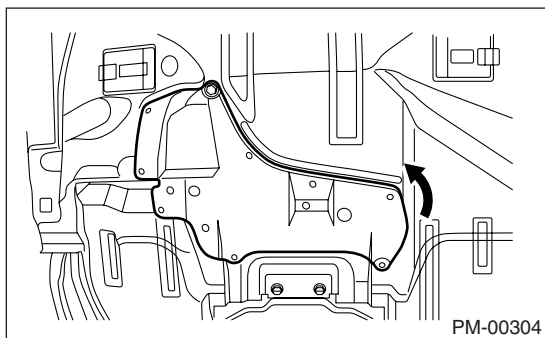

4) Drain engine oil by loosening the engine oil drain plug.

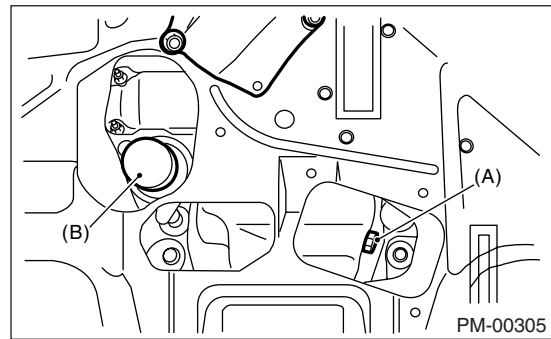

- (A) Engine oil drain plug
- (B) Oil filter

5) Replace the drain plug gasket with a new one.  
6) Tighten the engine oil drain plug after draining engine oil.

#### **Tightening torque:**

**44 N·m (4.5 kgf-m, 33 ft-lb)**

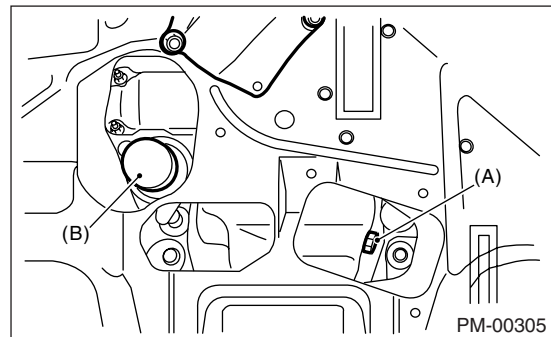

- (A) Engine oil drain plug
- (B) Oil filter

7) Fill engine oil through the level gauge up to center between the upper level and lower level. Place the vehicle on a level surface when checking oil level. Use engine oil of proper quality and viscosity, selected in accordance with the table in figure.

**Recommended oil:**

**API standard**

**SM specifications marked with “Energy saver or Energy saver II” (If an SM grade product is difficult to obtain, use an SJ grade product.)**

**ILSAC standard**

**GF-4 specifications with the mark of “Starburst”**

**Engine oil capacity:**

**Upper level:**

**Approx. 4.0 ℓ (4.2 US qt, 3.5 Imp qt)**

**Lower level:**

**Approx. 3.0 ℓ (3.2 US qt, 2.6 Imp qt)**

SAE (A)	(°C)	(°F)	Recommended (B)
-30	-20	-4	10W-30, 10W-40
-15	5	32	
0	32	86	5W-30 (B)
15	59	104	
30	86		
40	104		

PM-00347

- (A) Viscosity No. and applicable temperature
- (B) Recommended

The vehicle will start well even when temperatures are low or high by increasing the cranking speed by reducing viscous friction for the appropriate viscosity.

**NOTE:**

- Do not use any oil from a different manufacturer than that is in the engine when replacing oil. Use oil that matches the API standards and SAE viscosity number set by Subaru.
- It is acceptable to use oil having the viscosities described below if the vehicle is being used in desert locations or in excessive environments where temperatures are extremely high.

API standard: SM or SL

SAE viscosity No.: 30, 40, 10W-50, 20W-40, 20W-50

- 8) Close the engine oil filler cap.
  - 9) Start the engine and warm it up for a time.
  - 10) Stop the engine to inspect the oil level again.
- <Ref. to PM-7, INSPECTION, Engine Oil.>

## B: INSPECTION

- 1) Park the vehicle on a level surface.
- 2) Remove the oil level gauge and wipe away all of the oil.
- 3) Reinsert the level gauge all the way. Be sure that the level gauge is correctly inserted and in the correct position.
- 4) Remove the level gauge again and record the oil level. If the oil level is below the “L” line, add oil to bring the level up to the “F” line.

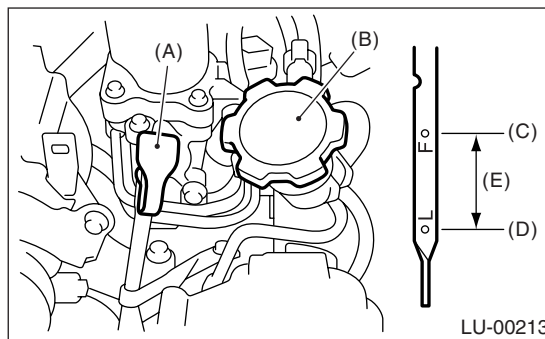

- (A) Engine oil level gauge
- (B) Engine oil filler cap
- (C) Upper level
- (D) Lower level
- (E) Approx. 1 ℓ (1.1 US qt, 0.9 Imp qt)

- 5) Wait for several minutes until the oil has returned to the oil pan after stopping the engine.
- 6) Immediately after driving or while the engine is warm, the engine oil level may be shown between the “F” line and the notch mark. This is caused by thermal expansion of engine oil.
- 7) To prevent overfilling of engine oil, do not add oil above “F” line when the engine is cold.