

Disc Brake Pad and Disc

PERIODIC MAINTENANCE SERVICES

20. Disc Brake Pad and Disc

A: INSPECTION

1. DISC BRAKE PAD AND DISC

- 1) Lift-up the vehicle and remove wheel.
- 2) Visually check the pad thickness through inspection hole of disc brake assembly. Replace the pad if necessary.

CAUTION:

When replacing a pad, always replace the pads for both the left and right wheels at the same time. Also replace the pad clips if they are twisted or worn.

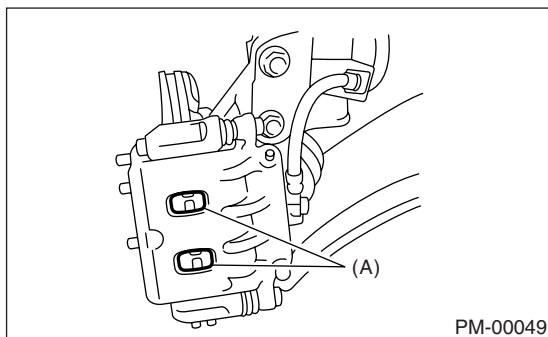

(A) Inspection hole

- 4) Remove the caliper body. <Ref. to BR-18, Front Disc Brake Assembly.> <Ref. to BR-24, Rear Disc Brake Assembly.>

- 5) Tighten the wheel nuts to secure disk rotor.

- 6) Set a dial gauge at a point less than 10 mm (0.39 in) from outer periphery of the rotor, and then measure the disk rotor runout.

Disc rotor runout limit:

Front

0.075 mm (0.0030 in)

Rear

0.070 mm (0.0028 in)

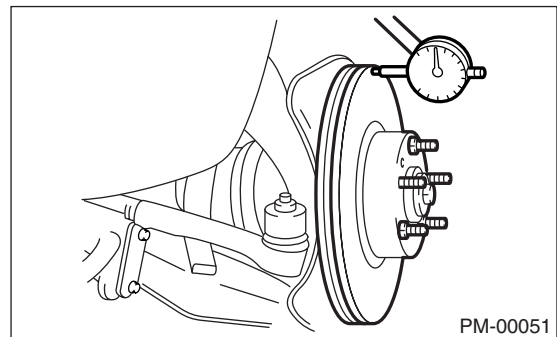

Pad thickness	mm (in)	
	Front	Rear
Standard	11 (0.43)	9 (0.35)
Wear limit	1.5 (0.059)	1.5 (0.059)

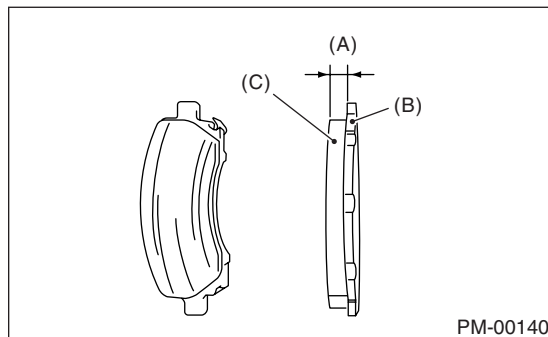

(A) Pad thickness

(B) Back metal

(C) Lining

- 3) Check the disc rotor, and correct or replace if it is damaged or worn.

Brake disc thickness	mm (in)	
	Front	Rear
Standard	24 (0.94)	10 (0.39)
Wear limit	22 (0.87)	8.5 (0.335)