

16.ATF

A: INSPECTION

CAUTION:

The level of ATF varies with fluid temperature. Pay attention to the fluid temperature when checking ATF level.

1) Raise the ATF temperature by driving a distance of 5 to 10 km (3 to 6 miles). Otherwise, idle the engine to raise ATF temperature to 70 — 80°C (158 — 176°F) on Subaru Select Monitor. <Ref. to 4AT(D)(diag)-15, READ CURRENT DATA, OPERATION, Subaru Select Monitor.>

2) Make sure the vehicle is level.

3) After selecting all positions (P, R, N, D, 3, 2, 1), set the select lever in "P" range. Measure the ATF level with engine idling for one or two minutes.

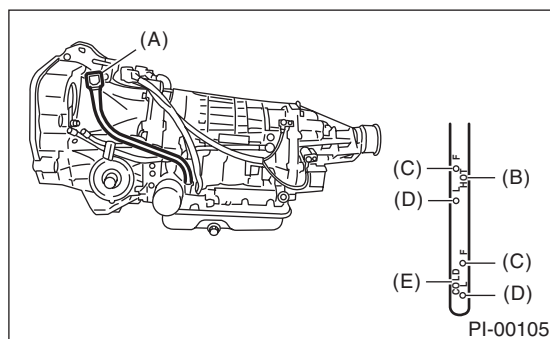

- (A) Level gauge
- (B) Inspection position when "HOT" (70 — 80°C (158 — 176°F))
- (C) Upper level
- (D) Lower level
- (E) Inspection position when "COLD" (20 — 30°C (68 — 86°F))

4) Make sure that ATF level is between the upper level and lower level.

NOTE:

When the transmission is hot, the level should be above the center of upper and lower marks, and when it is cold, the level should be found below the center of these two marks.

5) If the ATF level is below the center between upper and lower marks, add the recommended ATF until the ATF level reaches the upper level.

CAUTION:

- Use care not to exceed the upper limit level.
- Be sure not to add ATF up to the upper limit mark when the transmission is cold because that will be the cause for excessive filling of ATF, and will cause transmission failure.

6) Check the ATF level as instructed in step 3), after raising ATF temperature to 70 — 80°C (158 — 176°F) by running the vehicle or by idling the engine again.

7) Check the ATF for leaks.

Check for leaks inside of the transmission. If there are leaks, repair or replace the gasket, oil seals, plugs or other parts.

B: REPLACEMENT

1. AUTOMATIC TRANSMISSION FLUID

1) Drain the ATF by removing drain plug.

NOTE:

Before starting work, cool off the ATF well.

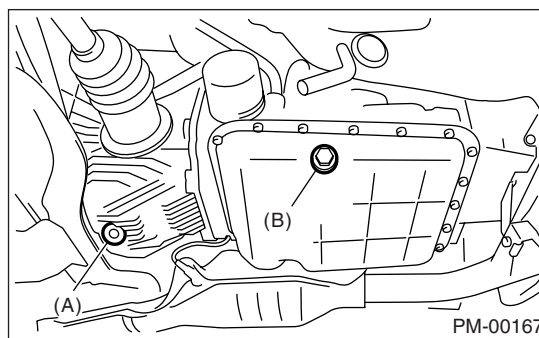

- (A) Front differential drain plug
- (B) ATF drain plug

2) Replace the gasket with new one, and then tighten the drain plug to specified torque.

Tightening torque:

25 N·m (2.5 kgf-m, 18.1 ft-lb)

3) Pour ATF through gauge hole.

Recommended fluid:

SUBARU ATF <Ref. to RM-4, RECOMMENDED MATERIALS, Recommended Materials.>

Fluid capacity:

Fill the same amount of ATF drained from ATF drain plug hole.

4) Check the ATF level. <Ref. to PM-25, INSPECTION, ATF.>

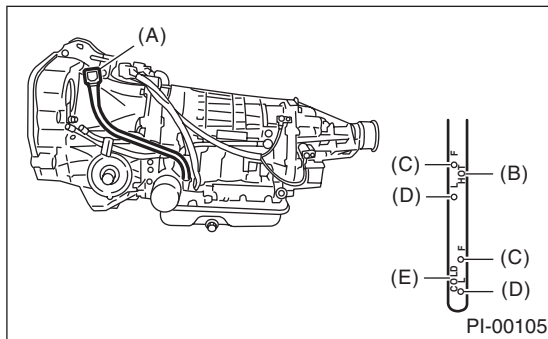

- (A) Level gauge
- (B) Inspection position when "HOT" (70 — 80°C (158 — 176°F))
- (C) Upper level
- (D) Lower level
- (E) Inspection position when "COLD" (20 — 30°C (68 — 86°F))

2. ATF FILTER

NOTE:

ATF filter needs replacement when it is physically damaged or ATF leaked.

For the replacement procedure of ATF filter, refer to "ATF FILTER". <Ref. to 4AT-63, ATF Filter.>