

General Description

REAR SUSPENSION

1. General Description

A: SPECIFICATION

Refer to "SPECIFICATIONS" in "FRONT SUSPENSION" section for rear suspension specifications. <Ref. to FS-2, SPECIFICATION, General Description.>

NOTE:

- Front toe-in, rear toe-in and front camber can be adjusted. Adjust if the value of toe-in or camber exceeds the tolerance range of the specification chart.
- Other items except for front toe-in, rear toe-in and front camber that are described in the specification chart cannot be adjusted. If other items exceed the tolerance range of the specification chart, check the suspension parts and connections for deformation. If defective, replace with new parts.

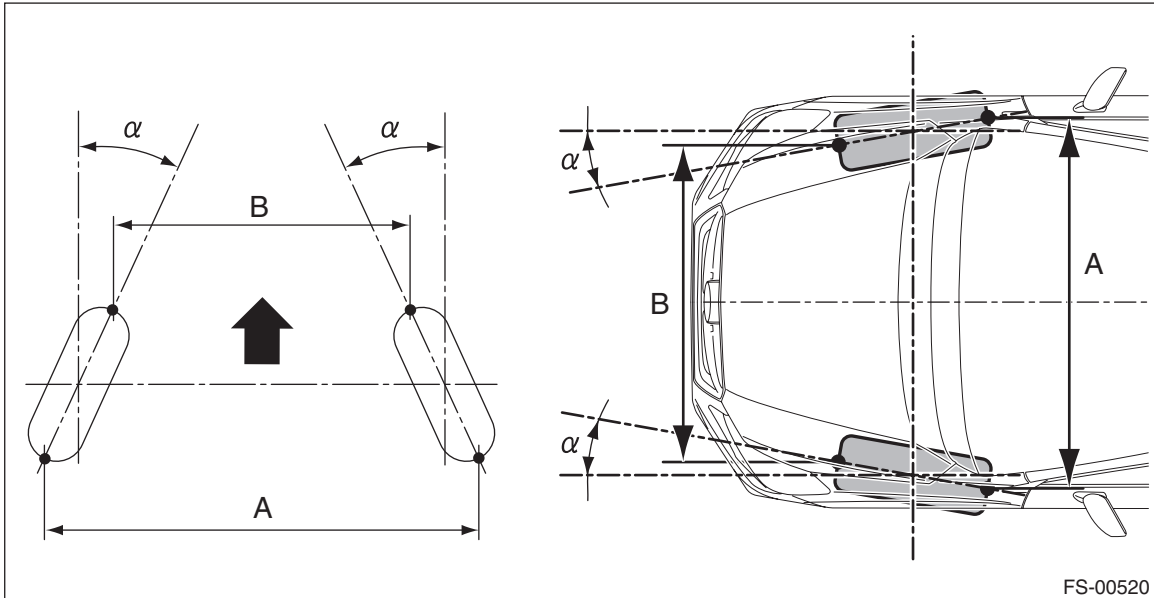

$A - B = \text{Positive: Toe-in, Negative: Toe-out}$

$\alpha = \text{Individual toe angles}$

B: COMPONENT

1. REAR SUSPENSION

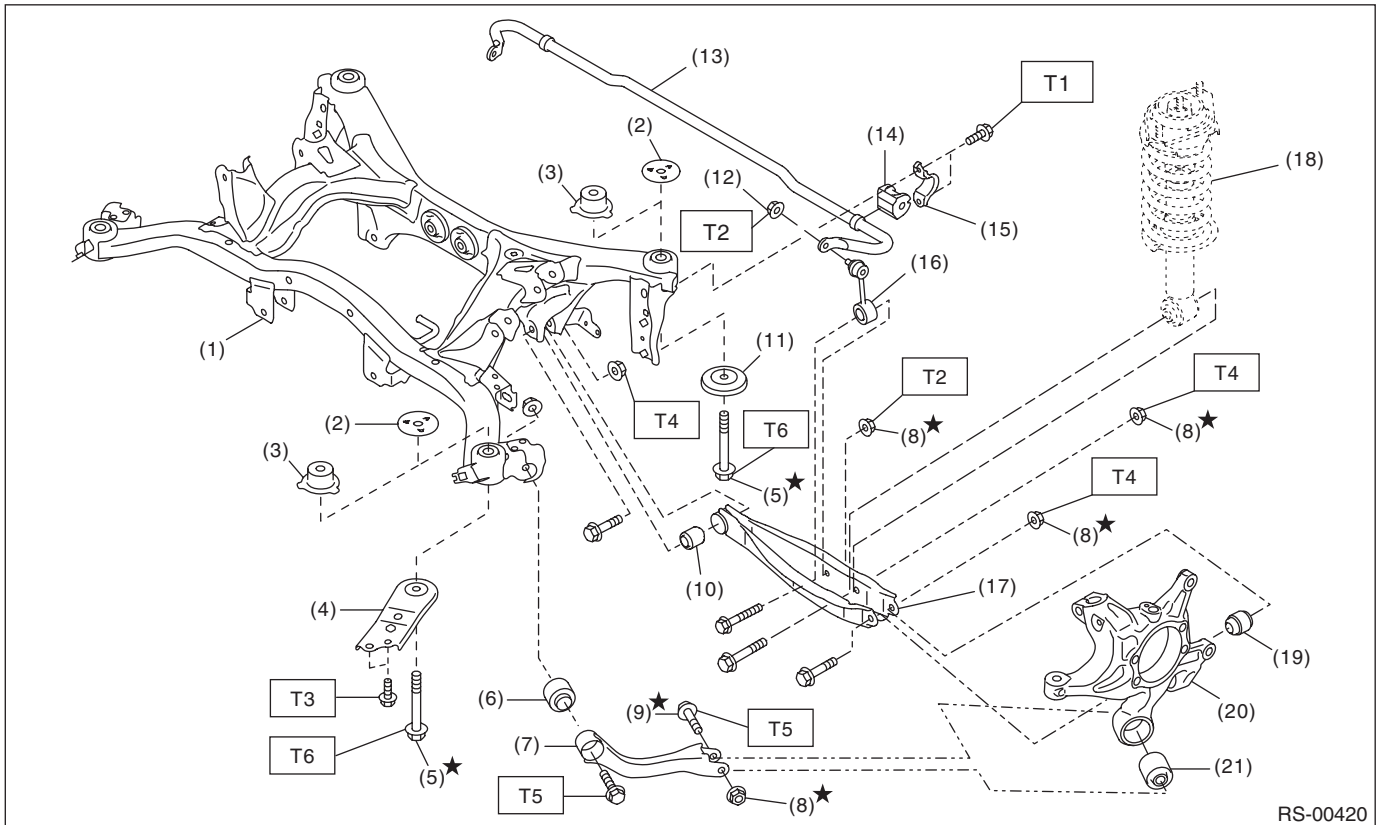

- | | | |
|------------------------------------|----------------------------------|------------------------------|
| (1) Rear sub frame ASSY | (11) Stopper LWR | (21) Bushing - trailing link |
| (2) Stopper UPR | (12) Flange nut | |
| (3) Stopper UPR (XV model) | (13) Rear stabilizer | |
| (4) Sub frame support | (14) Bushing - stabilizer | |
| (5) Flange bolt A | (15) Clamp - stabilizer bushing | |
| (6) Bushing A - trailing link | (16) Stabilizer link ASSY | |
| (7) Trailing link | (17) Rear lateral link ASSY | |
| (8) Self-locking nut | (18) Rear strut ASSY | |
| (9) Flange bolt B | (19) Bushing - rear axle housing | |
| (10) Bushing C - lateral link rear | (20) Housing ASSY - rear axle | |

Tightening torque: N-m (kgf-m, ft-lb)

T1: 30 (3.06, 22.1)

T2: 38 (3.87, 28.0)

T3: 70 (7.14, 51.6)

T4: 80 (8.16, 59.0)

T5: 90 (9.18, 66.4)

T6: 145 (14.79, 106.9)

General Description

REAR SUSPENSION

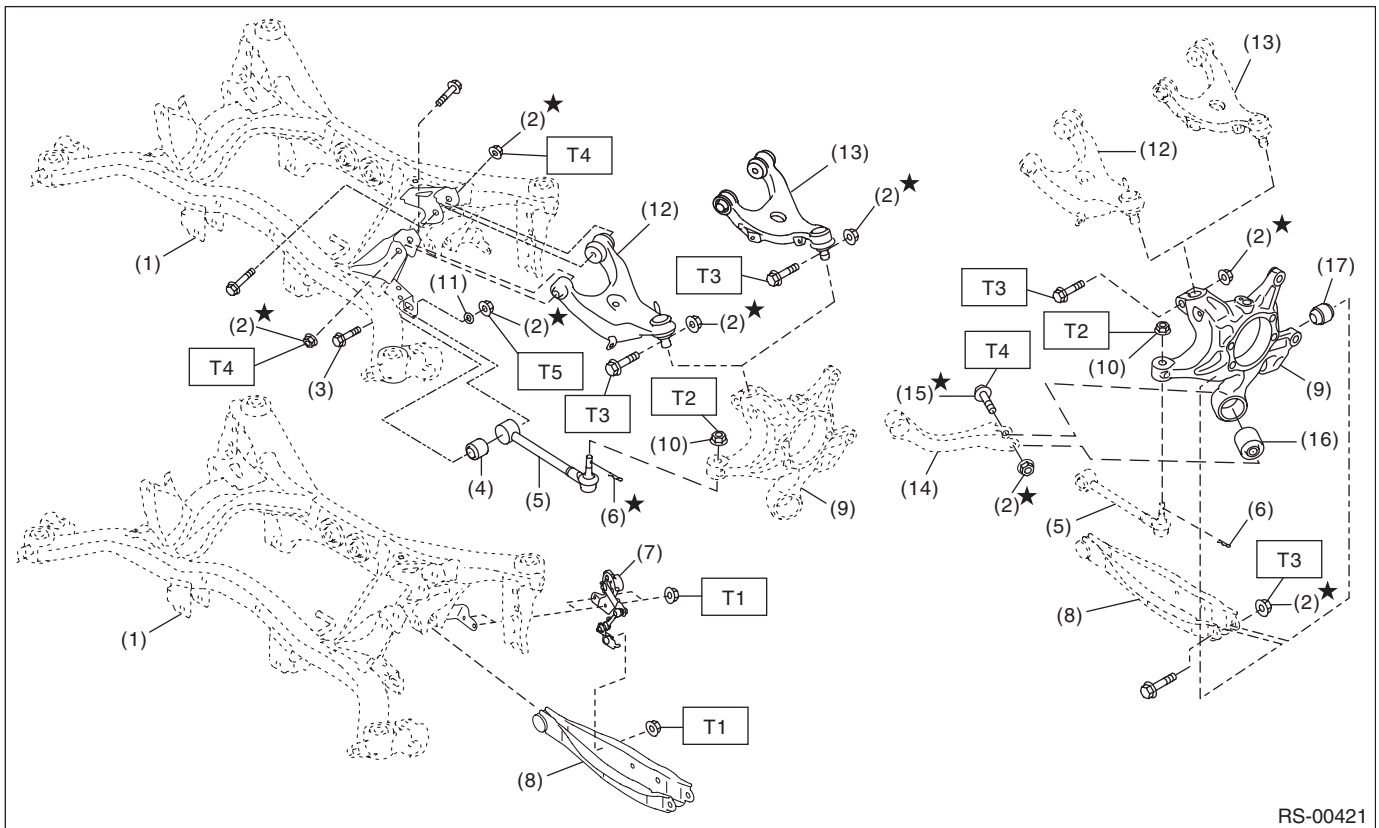

RS-00421

- | | | |
|---|-------------------------------------|----------------------------------|
| (1) Rear sub frame ASSY | (9) Housing ASSY - rear axle | (17) Bushing - rear axle housing |
| (2) Self-locking nut | (10) Flange nut | |
| (3) Adjusting bolt | (11) Adjusting washer | |
| (4) Bushing B - lateral link | (12) Rear upper arm ASSY | |
| (5) Lateral link ASSY - front | (13) Rear upper arm ASSY (XV model) | |
| (6) Snap pin | (14) Trailing link | |
| (7) Sensor ASSY - headlight beam leveler (models with auto headlight beam leveler only) | (15) Flange bolt | |
| (8) Lateral link ASSY - rear | (16) Bushing - trailing link | |

Tightening torque: N-m (kgf-m, ft-lb)

T1: 7.5 (0.76, 5.5)

T2: 60 (6.12, 44.3)

T3: 80 (8.16, 59)

T4: 90 (9.18, 66.4)

T5: 100 (10.20, 73.8)

2. REAR STRUT

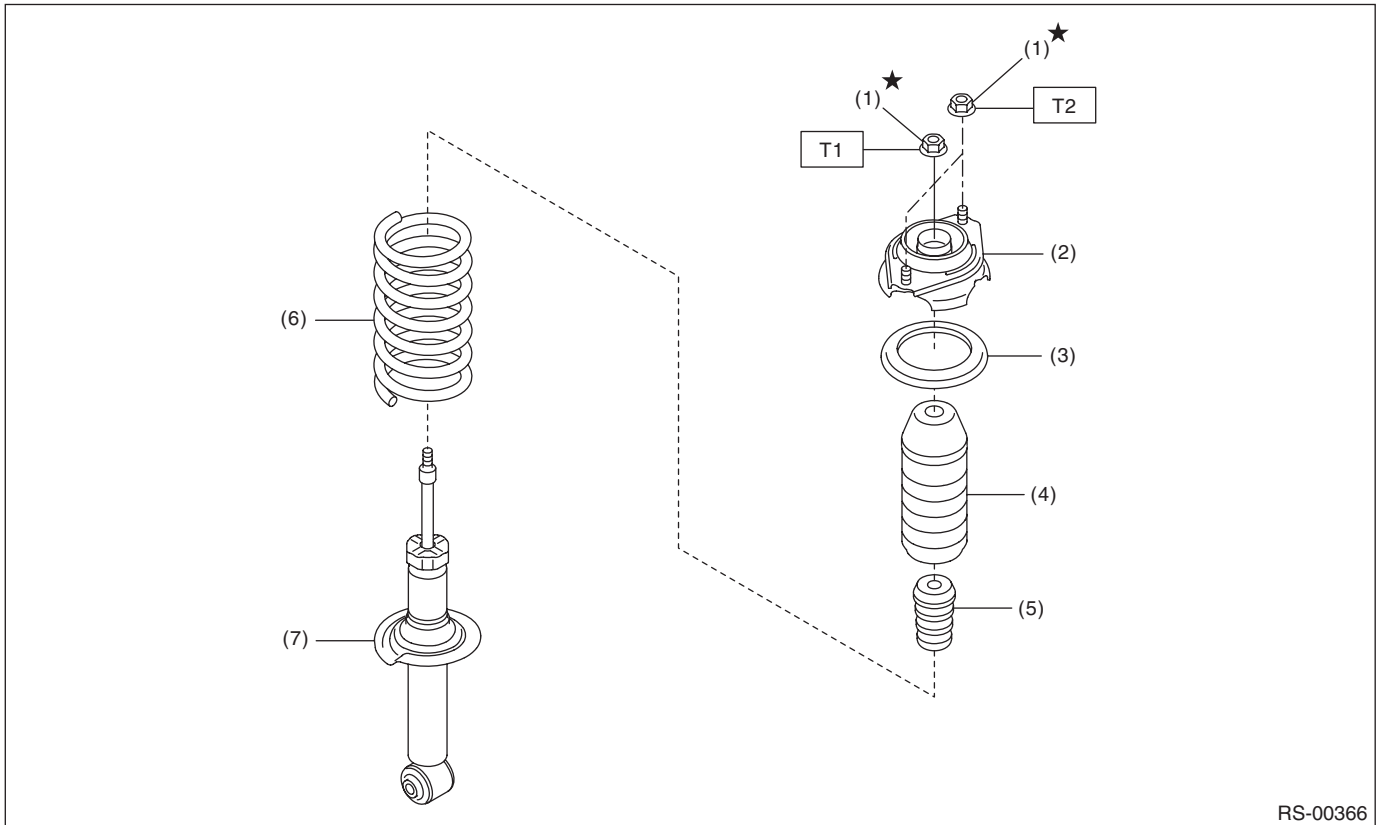

- | | |
|-----------------------------|--------------------------------|
| (1) Self-locking nut | (5) Helper - rear |
| (2) Strut mount - rear | (6) Coil spring - rear |
| (3) Rubber seat - strut UPR | (7) Shock absorber ASSY - rear |
| (4) Dust cover - rear strut | |

Tightening torque: N·m (kgf·m, ft·lb)

T1: 25 (2.55, 18.4)

T2: 30 (3.06, 22.1)

General Description

REAR SUSPENSION

C: CAUTION

Please clearly understand and adhere to the following general precautions. They must be strictly followed to avoid minor or serious injury to the person doing the work or people in the area.

1. EACH PROCEDURE

- Wear appropriate work clothing, including a helmet, protective goggles and protective shoes when performing any work.
- Before disposing of shock absorbers, be sure to bleed the gas out completely. Also, do not expose to flames or fire.
- Before removal, installation or disassembly, be sure to clarify the failure. Avoid unnecessary removal, installation, disassembly and replacement.
- Use SUBARU genuine grease etc. or equivalent. Do not mix grease etc. of different grades or manufacturers.
- Before securing a part on a vise, place cushioning material such as wood blocks, aluminum plate, or cloth between the part and the vise.
- Be sure to tighten fasteners including bolts and nuts to the specified torque.
- Place shop jacks or rigid racks at the specified points.
- When the suspension-related components have been replaced, perform "VDC sensor midpoint setting mode" of the VDC. <Ref. to VDC-19, VDC SENSOR MIDPOINT SETTING MODE, ADJUSTMENT, VDC Control Module and Hydraulic Control Unit (VDCCM&H/U).>

2. OIL

When handling oil, adhere to the following to prevent unexpected accident.

- Prepare container and waste cloths when performing work which oil could possibly spill. If oil spills, wipe it off immediately to prevent from penetrating into floor or flowing outside, for environmental protection.
- Follow all government regulations concerning disposal of refuse when disposing.

D: PREPARATION TOOL

1. SPECIAL TOOL

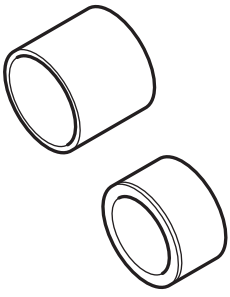
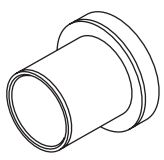
ILLUSTRATION	TOOL NUMBER	DESCRIPTION	REMARKS
 <p style="text-align: center;">ST20099PA010</p>	20099PA010	INSTALLER & REMOVER	<ul style="list-style-type: none"> • Used for replacing the bushing A - trailing link of the housing assembly - rear axle. • Used together with BUSHING REMOVER (20099FG000).
 <p style="text-align: center;">ST20099FG000</p>	20099FG000	BUSHING REMOVER	<ul style="list-style-type: none"> • Used for replacing the bushing A - trailing link of the housing assembly - rear axle. • Used together with base part of INSTALLER & REMOVER (20099PA000).

General Description

REAR SUSPENSION

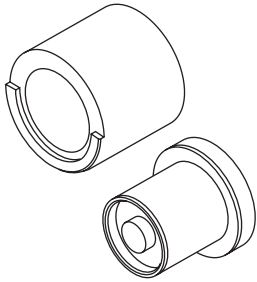
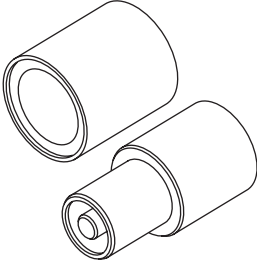
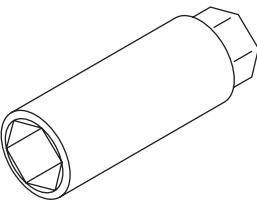
ILLUSTRATION	TOOL NUMBER	DESCRIPTION	REMARKS
 <p>ST20099AE000</p>	20099AE000	INSTALLER & REMOVER	Used for replacing the bushing B - lateral link.
 <p>ST20099AE010</p>	20099AE010	INSTALLER & REMOVER	Used for replacing the bushing C - lateral link.
 <p>ST20399FG000</p>	20399FG000	STRUT MOUNT SOCKET	<ul style="list-style-type: none"> • Used for removing and installing strut mount. • Used for checking torque of strut mount center nut.

2. GENERAL TOOL

TOOL NAME	REMARKS
Alignment tester	Used for measuring wheel alignment.
Toe-in gauge	Used for toe-in measurement.
Jack	Used for removing and installing suspension.
Bearing puller	Used for removing bushings.
Tie-rod ball joint puller	Used for disconnecting the lateral link assembly - front.
Coil spring compressor	Used for disassembling and assembling shock absorber.